

Seem™ 2 Indirect

Wall Mount | FSM2IW



BEFORE YOU BEGIN

- Luminaires must be installed by a qualified electrician (check with local and national codes for proper installation).
- To prevent electrical shock, disconnect electrical supply before installation or servicing.
- Contractor is responsible for adequately reinforcing walls and/or ceilings to support fixture weight.
- Focal Point, LLC accepts no responsibility for inadequately reinforced walls and/or ceilings.
- The information contained in this drawing is the sole property of Focal Point, LLC. Any reproduction in part or whole without the written permission of Focal Point, LLC is prohibited.

INSTRUCTION KEY

- ATTENTION**
- SEE ADDITIONAL INSTRUCTIONS**
- POWER OFF**
- POWER ON**

COMPONENT KEY

FOCAL POINT

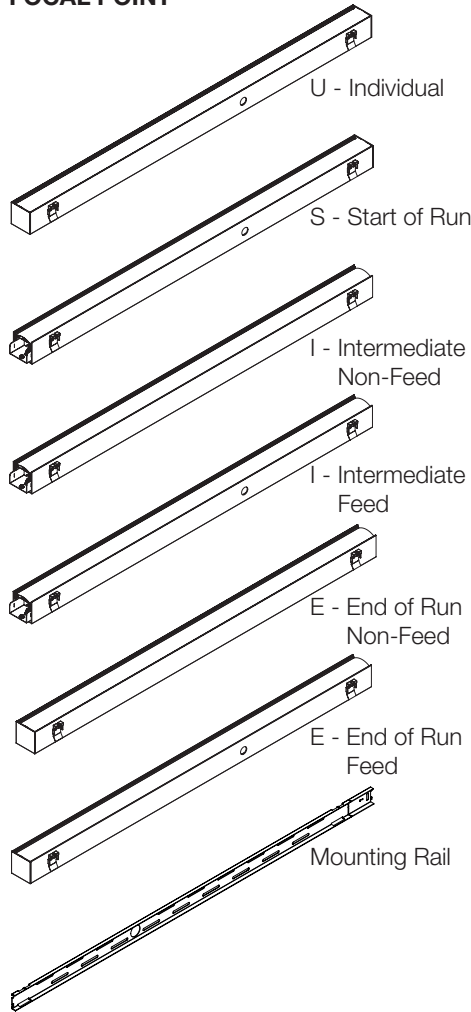

SHIPPED INSTALLED

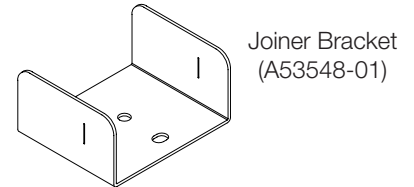

SHIPPED IN HARDWARE BAG



Configurations are run specific, please consult factory drawings before beginning installation.

INDIVIDUAL UNIT INSTALLATION FOLLOW STEPS 1-6, 11 & 12

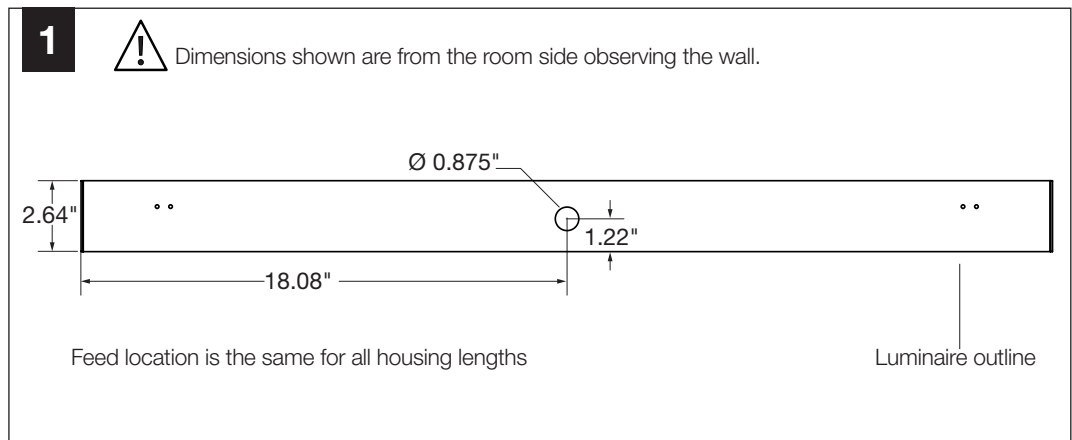
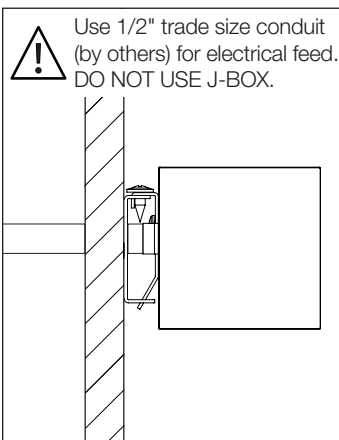

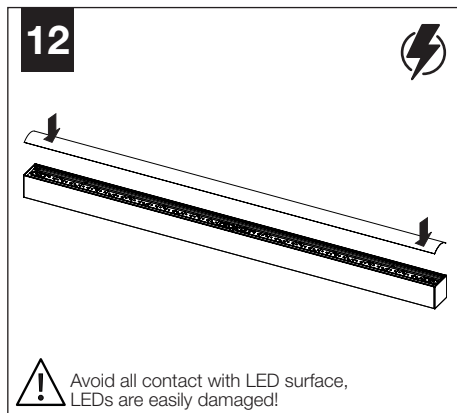
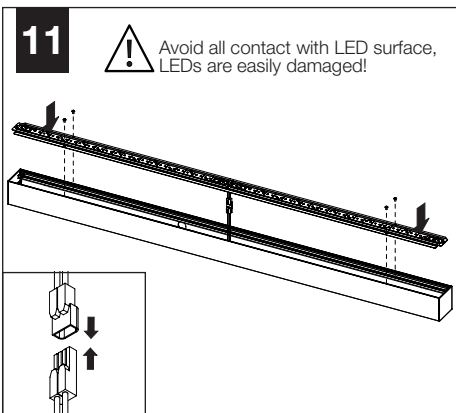
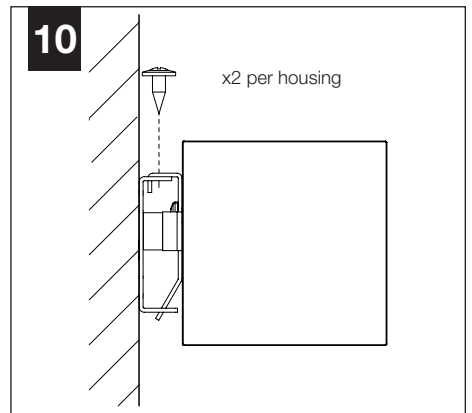
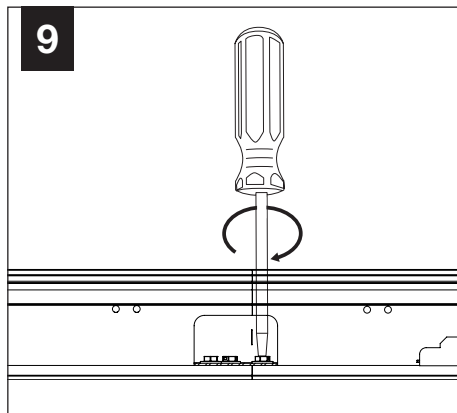
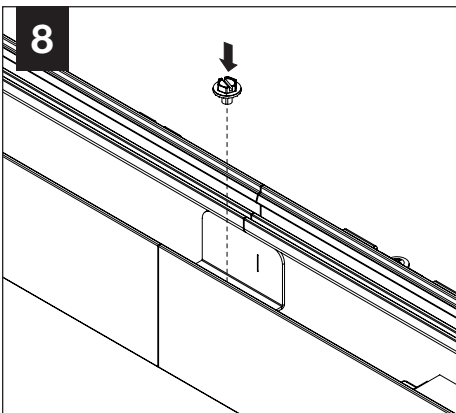
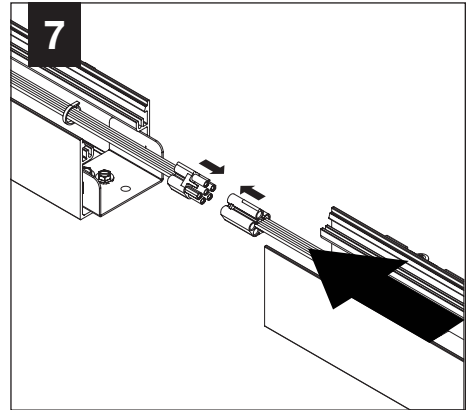
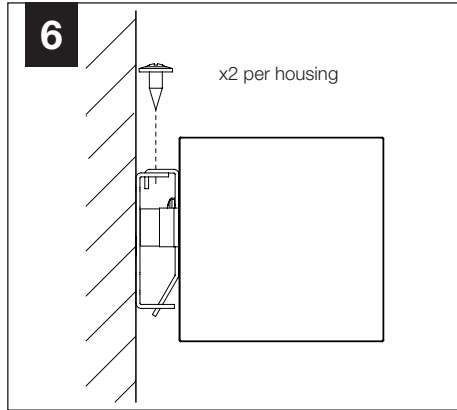
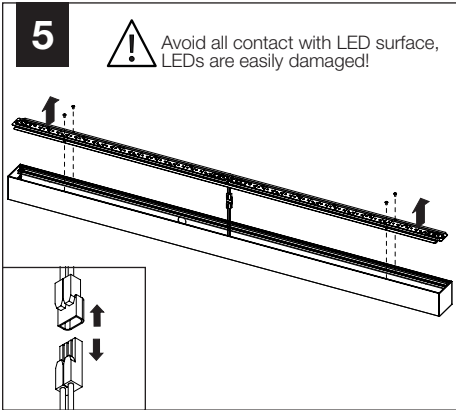
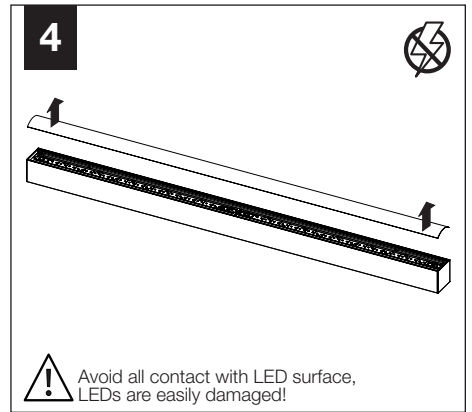
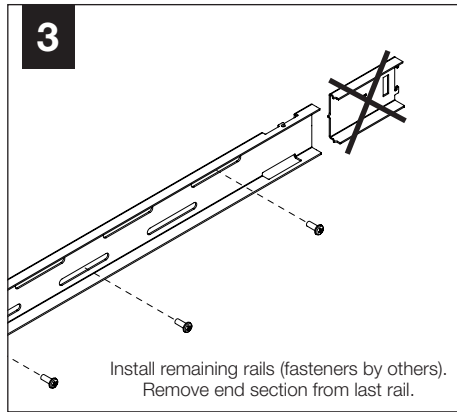
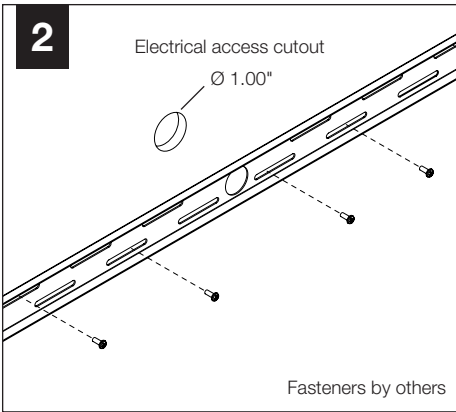

DRIVER SERVICE

